

SPEED CONTROL MOTOR - SU SERIES

6W

□60mm

K6□S6N□-SU

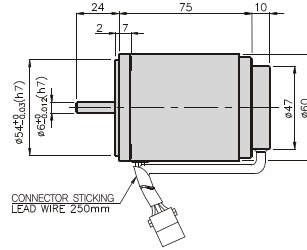
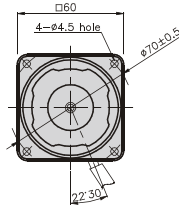

SPECIFICATIONS

6W continuous rating, four poles

Model	Voltage (V)	Frequency (Hz)	Speed Range (rpm)	Permissible Torque		Start T. (N*m/Kgf*cm)	Current (A)	Condenser (μF)
				1200rpm (N*m/Kgf*cm)	90rpm (N*m/Kgf*cm)			
K6□6NJ-SU	100	50	90 ~ 1400	0,05/0,5	0,03/0,3	0,029/0,29	0,28	3
		60	90 ~ 1700					
K6□6NU-SU	110	60	90 ~ 1700	0,05/0,5	0,03/0,3	0,03/0,3	0,24	2
	115							
K6□6NL-SU	200	50	90 ~ 1400	0,05/0,5	0,029/0,29	0,03/0,3	0,19	0,8
		60	90 ~ 1700					
K6□6NC-SU	220	50	90 ~ 1400	0,05/0,5	0,029/0,29	0,029/0,29	0,2	0,6
		60	90 ~ 1700					
	230	50	90 ~ 1400					
		60	90 ~ 1700					
K6□6ND-SU	240	50	90 ~ 1400	0,05/0,5	0,029/0,29	0,03/0,3	0,21	0,5

* □ : SHAFT SHAPE (S : STRAIGHT, G : PINION)

RATED TORQUE OF GEARHEAD

● Single-phase 100V/115V

unit = above : N · m / below : kgfcm

Model Motor/Gearhead	Ratio Speed(rpm)	3	3,6	5	6	7,5	9	10	12,5	15	18	20	25	30	36	40	50	60	75	90	100	120	150	180	200	250
		K6□6N□-SU K6G□B(C)	1200	0,12 1,2	0,15 1,5	0,20 2,0	0,24 2,4	0,30 3,0	0,36 3,6	0,41 4,1	0,51 5,1	0,61 6,1	0,73 7,3	0,73 7,3	0,91 9,1	1,09 10,9	1,31 13,1	1,46 14,6	1,64 16,4	1,97 19,7	2,46 24,6	2,95 29,5	3 30	3 30	3 30	3 30
	90	0,07 0,7	0,08 0,8	0,12 1,2	0,14 1,4	0,18 1,8	0,21 2,1	0,23 2,3	0,26 2,6	0,32 3,2	0,42 4,2	0,42 4,2	0,53 5,3	0,63 6,3	0,76 7,6	0,85 8,5	0,95 9,5	1,14 11,4	1,43 14,3	1,71 17,1	1,90 19,0	2,28 22,8	2,85 28,5	3 30	3 30	3 30

● Single-phase 200V/240V

unit = above : N · m / below : kgfcm

Model Motor/Gearhead	Ratio Speed(rpm)	3	3,6	5	6	7,5	9	10	12,5	15	18	20	25	30	36	40	50	60	75	90	100	120	150	180	200	250
		K6□6N□-SU K6G□B(C)	1200	0,12 1,2	0,15 1,5	0,20 2,0	0,24 2,4	0,30 3,0	0,36 3,6	0,41 4,1	0,51 5,1	0,61 6,1	0,73 7,3	0,73 7,3	0,91 9,1	1,09 10,9	1,31 13,1	1,46 14,6	1,64 16,4	1,97 19,7	2,46 24,6	2,95 29,5	3 30	3 30	3 30	3 30
	90	0,07 0,7	0,08 0,8	0,12 1,2	0,14 1,4	0,18 1,8	0,21 2,1	0,23 2,3	0,29 2,9	0,35 3,5	0,42 4,2	0,42 4,2	0,53 5,3	0,63 6,3	0,76 7,6	0,85 8,5	0,95 9,5	1,14 11,4	1,43 14,3	1,71 17,1	1,90 19,0	2,28 22,8	2,85 28,5	3 30	3 30	3 30

- * Gearhead and decimal gearhead are sold separately.
- * The code in □ of gearhead model is for gear ratio.
- * ■ color indicates that the output shaft of the geared motor rotates in the same direction as the output shaft of the motor. Others indicate rotation in the opposite direction.
- * If you are to have less ratio than the ratio in the table, you can install the decimal gearhead, which has one tenth of the ratio, between the gearhead and the motor. In this case, the permissible torque is 3N · m/30kgfcm.
- * RPM is based on motor's synchronous rpm (50HZ:1500rpm, 60HZ:1800rpm) and calculated by dividing gear ratio. Actual rpm is 2~20% less than indicating rpm according to load size.

GEARHEADS

CONNECTION DIAGRAMS

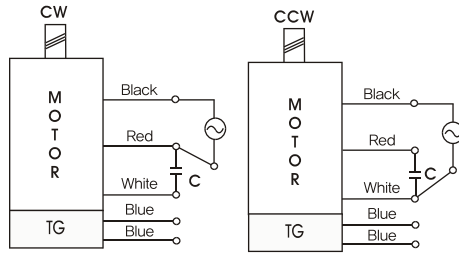

※The direction of motor rotation is as viewed from the front shaft end of the motor

DIMENSIONS

K6G□B(C)



K6IG6N□-SU + K6G□B(C)



DECIMAL GEARHEAD

K6G10BX

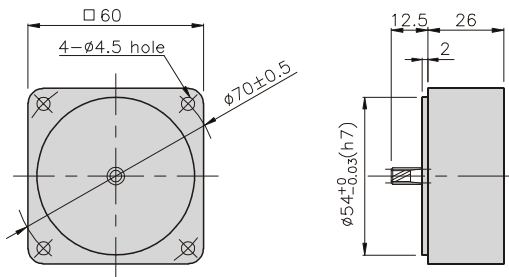

GEARHEAD

K6G□B(C)

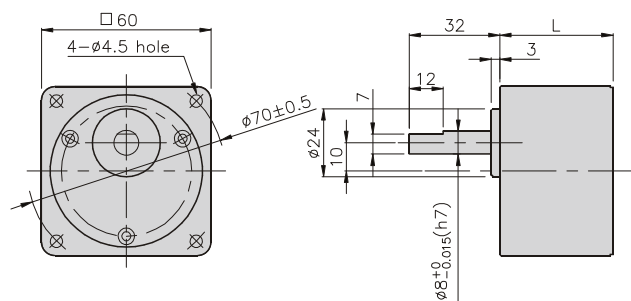

DIMENSION TABLE

PART No.	L	Application Model	Mounting BOLT
01	32	K6G3~18B(C)	M4 P0,7 X 50
02	40	K6G20~250B(C)	M4 P0,7 X 60
03	32	K6G10BX	M4 P0,7 X 85

WEIGHT

PART	WEIGHT(kg)	
MOTOR	0,79	
DECIMAL GEAR HEAD	0,22	
GEAR HEAD	K6G3~18B(C)	0,26
	K6G20~40B(C)	0,33
	K6G50~250B(C)	0,36

K6IG6N□-SU + K6G□B(C)

